

# ZESTO

## Electric Conveyor Oven CE 6032



- \* 32" (81cm) conveyor belt.
- \* Stainless Steel Construction.
- \* Front mount controls for easy view and access.
- \* Electronic temperature control with digital read-out.
- \* Variable digital speed control on conveyor belt.
- \* Cook time from 1 - 20 minutes.
- \* Reversible conveyor belt direction.
- \* Thermally insulated for energy efficiency.

- \* High velocity precision targeted air flow distribution panels for consistent repeatable baking results.
- \* Stackable (up to 2 units high).
- \* Super efficient electric tubular elements.
- \* Removable front panel, crumb tray, top and bottom air flow distribution panels for easy cleaning.
- \* Legs with locking casters (17", 23" or 29" available)



**Ideal for a variety of cooking applications including pizza, seafood, omelettes and other egg dishes, pre-cooked meats, cookies, bakery products, pita breads, heating plated Mexican food and hot submarine sandwiches.**

# Electric Conveyor Oven CE 6032



Conforms to: ANSI / UL Std. 197  
Conforms to: CSA C22.2 Std. 109

Conforms to:  
Std. NSF-4

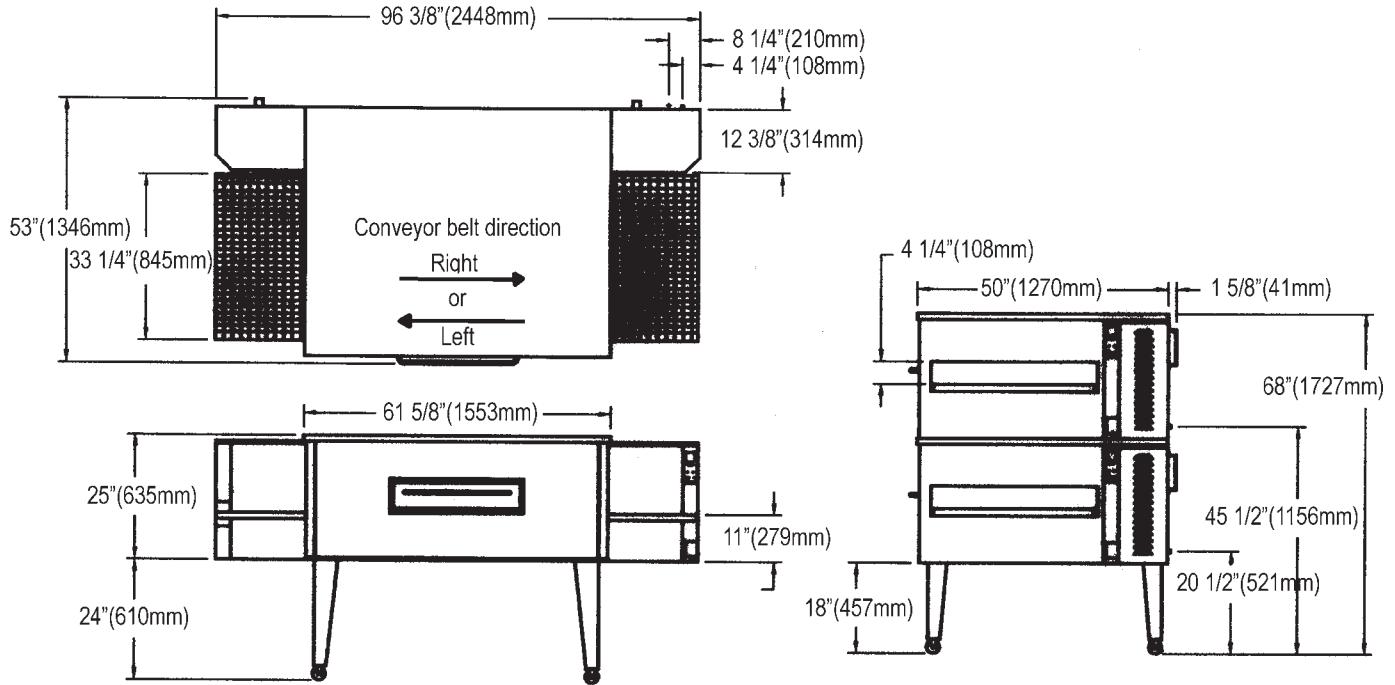

<b>Approximate production per hour / per section / bake time in minutes (6032)</b>							
<b>Pan diameter</b>	<b>5 min</b>	<b>6 min</b>	<b>6.45 min</b>	<b>7 min</b>	<b>7.5 min</b>	<b>8 min</b>	<b>9 min</b>
<b>6" (15 cm)</b>	632	531	495	455	423	397	353
<b>8" (20 cm)</b>	357	298	277	255	237	223	198
<b>10" (25 cm)</b>	227	190	176	161	151	141	125
<b>12" (30 cm)</b>	157	131	121	111	104	98	86
<b>14" (35 cm)</b>	115	95	89	81	76	71	64
<b>16" (40 cm)</b>	88	73	67	61	58	53	48

Cooking Chamber 60" (152.4 cm) long X 32" (81 cm) deep

<b>Model</b>	<b>Electric elements/kw</b>	<b>Exterior dimensions</b>	<b>Length of belt</b>	<b>Voltages / Amps</b>	<b>Ship wt..</b>
CE 6032	(9 X 4.5 kw) = 40.5 kw	96"L x 50"D 244cm x 127cm	96"L x 32"D 244cm x 81cm	220-240v / 1 $\phi$ (192 - 177 amps) ** 400v / 3 $\phi$ (66.5 amps) ** 600v / 3 $\phi$ (47 amps)	208-220v / 3 $\phi$ (120 - 114 amps) ** 480v / 3 $\phi$ (56.7 amps) ** Optional at extra cost
					1090 lbs 495 kg

Available in 50 or 60 cycles. Amperage could vary if input volts are not the same as indicated.

**ZESTO** FOOD EQUIPMENT MANUFACTURING INC.  
MANUFACTURIER D'EQUIPEMENT EN ALIMENTATION INC.

6450 HUTCHISON, MONTREAL, QC, CANADA H2V 4C8  
TEL(514)278-4621 FAX(514)278-4622  
e-mail info@zesto.ca www.zesto.ca

SPECIFICATIONS SUBJECT TO CHANGE WITHOUT NOTICE.

LES SPÉCIFICATIONS SONT SUJETS À CHANGEMENT SANS AVIS.