

ZESTO

Open Gas Deck Oven

Six Models Available.

Small footprint.

Stackable with our standard deck ovens.

- * **Stainless Steel Top, Sides and Front.**
- * **Long life super efficient stainless steel tubular burners every 12".**
- * **Interior top heat damper control.**
- * **120v, 208v, 220v or 240v electrical connection available.**
- * **Side or rear gas connection 1/2" npt.**
- * **Front large plate shelf.**
- * **Fully insulated to conserve energy.**
- * **Fits through 34" doorway.**
- * **12", 18", 24" or 30" legs 12ga. steel painted legs available. Must specify size when ordering oven.**
- * **1 1/2" refractory stone hearth over metal undersheets 12ga. steel with 1 1/2" airspace between burners and flame diverters for even heat throughout.**
- * **Canopy or direct flue diverter available. Please specify when ordering oven.**

AVAILABLE OPTIONS

- * **Stainless steel legs.**
- * **Locking casters for legs.**

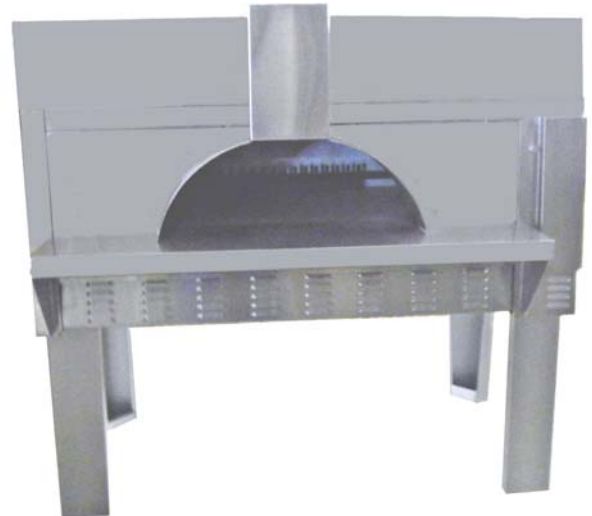

Cooking pizza & other products



Stone hearth & undersheets

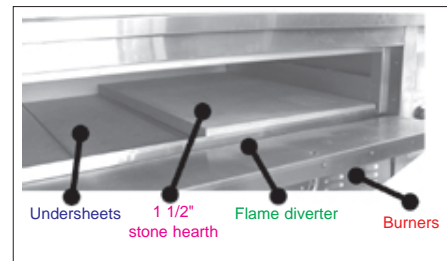

Flame diverter & air space

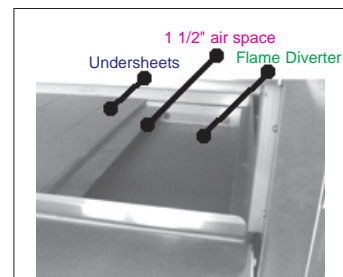

Open Gas Deck Oven

Gas Connection: Equipped with 1/2" NPT gas connection on side and rear.

Stacking: With our standard Deck Ovens stack evenly with no wasted space between top and bottom units. Stacked units must be connected seperately.

Ventilation: Proper ventilation is required.

Installation: Oven comes in two parts plus the legs. Oven body is 26" and the top is 10".

Adjustable damper to control top heat



Models	Cooking surface
309-0	36" wide X 36" deep
312-0	48" wide X 36" deep
315-0	60" wide X 36" deep
<i>Space Saver Model</i>	
309-0 SS	36" wide X 30" deep
312-0 SS	48" wide X 30" deep
315-0-SS	60" wide X 30" deep

Available in Natural or Propane Gas

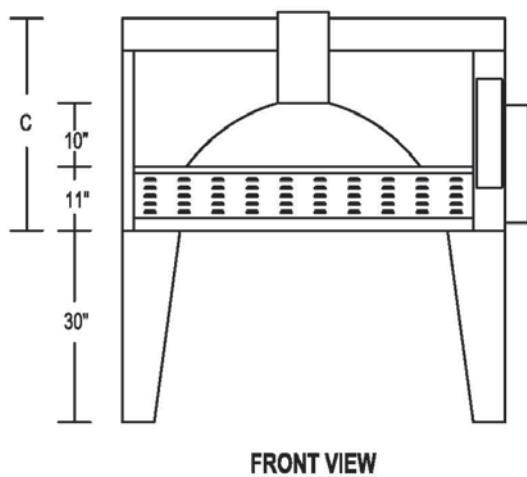
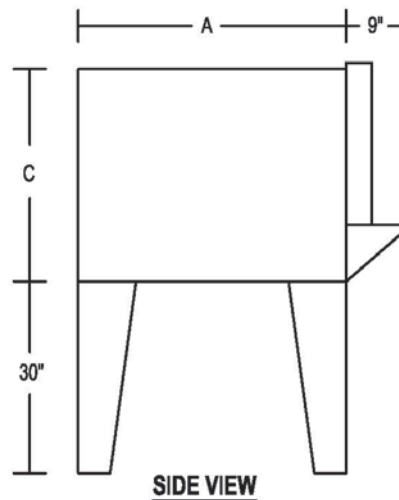
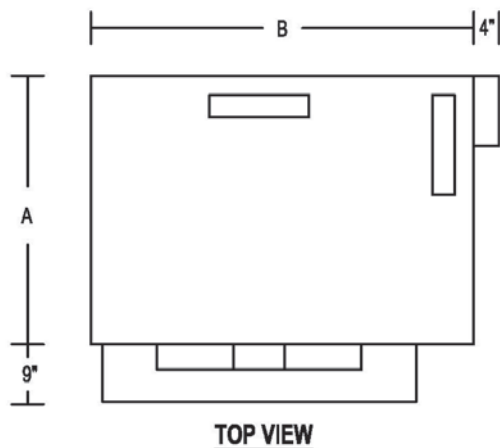

Models	"A" Depth <i>Front Shelf 9"</i>	"B" Width <i>Damper control 4"</i>	"C" Height	B.T.U
309-0	42" + 9"	48" + 4"	36" + legs	82,000
312-0	42" + 9"	60" + 4"	36" + legs	102,000
315-0	42" + 9"	72" + 4"	36" + legs	122,000
<i>Space Saver Model</i>				
309-0 SS	36" + 9"	48" + 4"	36" + legs	82,000
312-0 SS	36" + 9"	60" + 4"	36" + legs	102,000
315-0-SS	36" + 9"	72" + 4"	36" + legs	122,000

Available Legs 12", 18", 24" or 30"

ZESTO FOOD EQUIPMENT MANUFACTURING INC.
MANUFACTURIER D'EQUIPEMENT EN ALIMENTATION INC.

4575 PARK AVENUE, MONTREAL, QC, CANADA H2V 4C8
TEL(514)278-4621, (514) 448-1600 FAX(514)278-4622
e-mail info@zesto.ca www.zesto.ca

SPECIFICATIONS SUBJECT TO CHANGE WITHOUT NOTICE.

LES SPÉCIFICATIONS SONT SUJETS À CHANGEMENT SANS AVIS.