

ZESTO

Gas Conveyor Oven CG 6532 DD



Each standard oven is equipped with the following:

- * One electronic digital readout temperature control, 100°F (37.7°C) to 600°F (315°C).
- * Two 32" conveyor belts, each belt with an individual variable digital speed control (range 1 min. to 20 min.)
- * High velocity precision targeted air flow distribution system for consistent, repeatable even baking results.
- * Stainless Steel Front, Top & Sides.
- * Reversible conveyor belt drive motor.
- * Right side mounted controls for easy view and access.
- * Removable front panel for easy cleaning.
- * Removable top and bottom air flow stainless steel distribution panels for easy cleaning.

Ideal for a variety of cooking applications including pizza, seafood, omelettes and other egg dishes, pre-cooked meats, cookies, bakery products, pita breads, heating plated Mexican food and hot submarine sandwiches.

OPTIONS & CONFIGURATIONS AVAILABLE

Single Oven

- * Two 32"(812mm) belts, (standard configuration) giving 2 different time cook zones
- * One 32"(812mm) belt, two 16"(406mm) split belts giving 3 different time cook zones
- * Four 16"(406mm) split belts, giving 4 different time cook zones
- * 24"(609mm) high stainless steel 2"(50mm) tube stand with four locking casters.
- * Front access doors.

Stacked Double Oven

- * Four 32"(812mm) belts, (standard configuration) giving 4 different time cook zones
- * Three 32"(812mm) belts, two 16"(406mm) split belts giving 5 different time cook zones
- * Two 32"(812mm) belts, four 16"(406mm) split belts giving 6 different time cook zones
- * One 32"(812mm) belt, six 16"(406mm) split belts giving 7 different time cook zones
- * Eight 16"(406mm) split belts giving 8 different time cook zones
- * 9"(228mm) high or 17"(304mm) high stainless steel 2"(50mm) tube stand with four locking casters.
- * Front access doors.

Gas Conveyor Oven CG 6532 DD



Conforms to: ANSI Std. Z83.11
Conforms to: CGA Std. 1.8



Conforms to:
Std. NSF-4

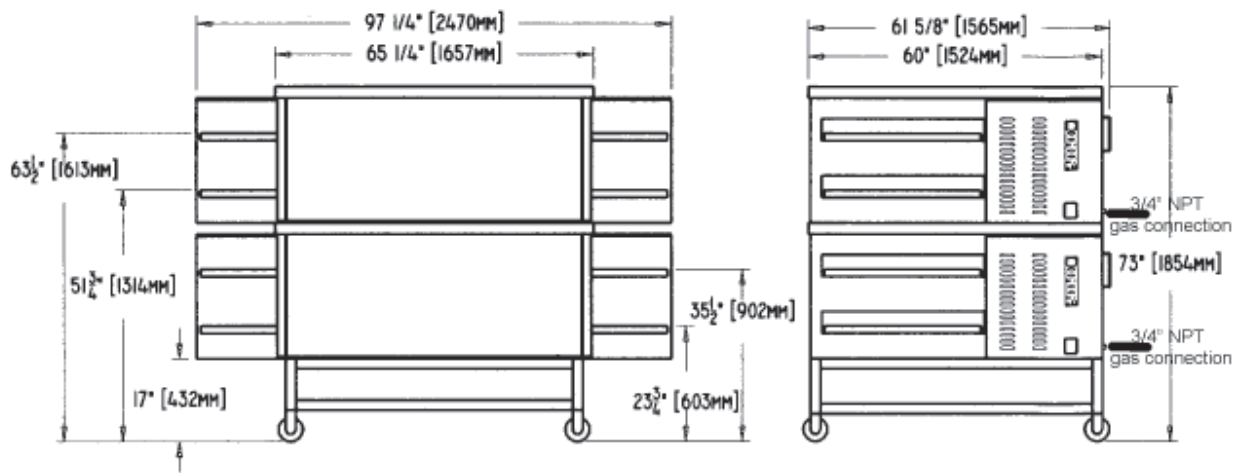
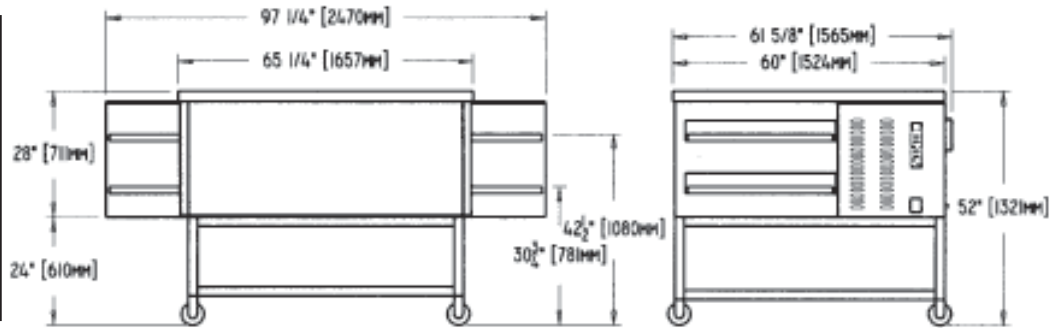
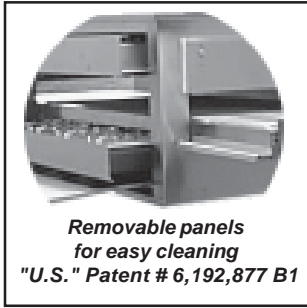

Approximate Production per hour / Bake time in minutes

Model CG 6532 DD (one oven cavity, two 32" belts)

Pan Diameter	5 min	6 min	6.45 min	7 min	7.5 min	8 min	9 min
6" (15 cm)	1276	1062	990	910	846	794	706
8" (20 cm)	714	596	554	510	474	446	396
10" (25 cm)	454	380	352	322	302	282	250
12" (30 cm)	314	262	242	222	208	196	172
14" (35 cm)	230	190	178	162	152	142	128
16" (40 cm)	176	146	134	122	116	106	96

Model CG 6532 DD stacked (two oven cavities four 32" belts)

Pan Diameter	5 min	6 min	6.45 min	7 min	7.5 min	8 min	9 min
6" (15 cm)	2552	2124	1980	1820	1692	1588	1412
8" (20 cm)	1428	1192	1108	1020	948	892	792
10" (25 cm)	908	760	704	644	604	564	500
12" (30 cm)	628	524	484	444	416	392	344
14" (35 cm)	460	380	356	324	304	284	256
16" (40 cm)	352	292	268	244	232	212	192

Model	CG 6532 DD
Dimensions	97 1/4" Long (2470mm) 61 1/2" Wide (1562mm)
Cooking chamber	65" Long (1651mm) 32" Wide (813mm)
Belt dimensions	96" Long (2438mm) 32" Wide (813mm)
B.T.U. / hour	225,000 per oven
Electrical	25 Amps 208 / 220 volts, 50 or 60 cycles
Weight	1835 lbs (515kg)

Available in Natural or Propane Gas. Equipped with 3/4" (19mm) NPT gas connection at rear.

ZESTO FOOD EQUIPMENT MANUFACTURING INC.
MANUFACTURIER D'EQUIPEMENT EN ALIMENTATION INC.

6450 HUTCHISON, MONTREAL, QC, CANADA H2V 4C8
TEL(514)278-4621 FAX(514)278-4622
e-mail info@zesto.ca www.zesto.ca

SPECIFICATIONS SUBJECT TO CHANGE WITHOUT NOTICE.

LES SPÉCIFICATIONS SONT SUJETS À CHANGEMENT SANS AVIS.